

CLASICAIR BENCH

INDOOR / OUTDOOR

Who would say that through a blade from a windmill could be obtained much of the urban and domestic furniture?

SOSTYL AIR[®]

GIVE A SECOND LIFE TO THE SO CALLED EVIL WASTE OF ENERGY WIND POWER FOR ITS RECONVERSION INTO A WIDE RANGE OF PRODUCTS LIKE,

BENCHES, FLOWERPOTS, TABLES, CHAIRS, LAMPS...

ECOLOGICAL AND SUSTAINABLE



DESCRIPTION: Classic style bench, suitable for outdoor use.

Measures*:	Height	87 cm
	Width	50 cm
	Length	200 cm

Approximate measurements

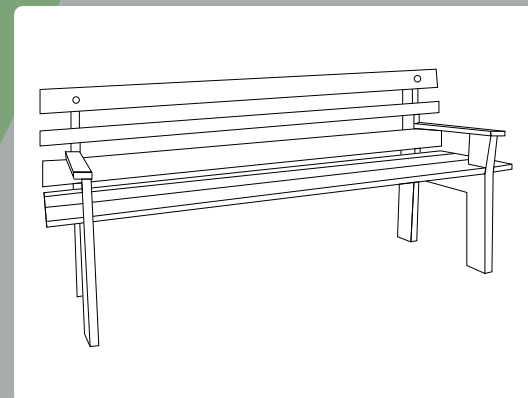

Colour: Basic presentation in white and black color. The customer can customize the external color of the bench according to their needs, with a cost of 50€, this option being free of charge for orders of 5 units or more. Sustainable production

*There is the option of of customised measurements

Ventos Metódicos Reciclagem LDA.
Polígono Industrial da Lagoa. Rua das Cruzes, 484
4950-850 Monção. Portugal

info@sostylair.eu

Teléfono: +34 62686 86 30



CLASICAIR Bench

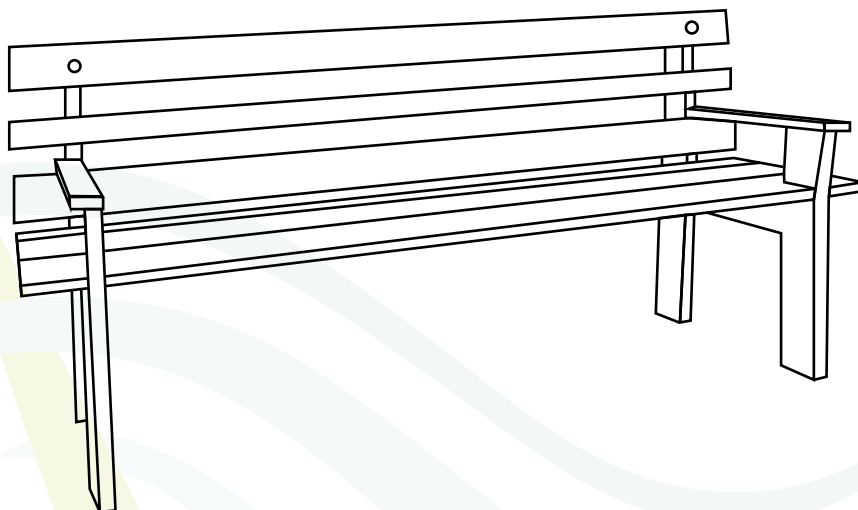



REF: 0006

 **Measures***

Length: 200cm
Height: 87cm
Width: 50cm

 **Weight**
30 Kg

 **Endurance**
400 Kg/m2

 **Paint Temperature**
Max. 85°C

 **Color**
White
Black
Customised

 **Content**

2 Seat bases
2 Rear bases
2 Legs
1 Leg brace
24 Screws

 **Packaging Measures**

Length: 210cm
Height: 40cm
Width: 60cm

 **Warranty**
2 Years

*Approximate measurements

Made with recycled materials. 95% sustainable.



Poligono Industrial da Lagoa
Rua das Cruzes, n° 484
4950-850 Monção
Portugal

 www.ventosmetodicos.com
 +351 258 099 691





GOYO PRO BENCH

INDOOR / OUTDOOR

Who would say that through a blade from a windmill could be obtained much of the urban and domestic furniture?

SOSTYL AIR[®]

GIVE A SECOND LIFE TO THE SO CALLED EVIL WASTE OF ENERGY WIND POWER FOR ITS RECONVERSION INTO A WIDE RANGE OF PRODUCTS LIKE,

BENCHES, FLOWERPOTS, TABLES, CHAIRS, LAMPS...

ECOLOGICAL AND SUSTAINABLE



DESCRIPTION: Bench for indoor or outdoor use, with two towers on both sides and space to place plants or to store objects.

Measures*:	Height	95 cm
	Width	50 cm
	Length	224 cm
	Approximate measurements	

Colour: Basic presentation in white and black color. The customer can customize the external color of the bench according to their needs, with a cost of 50€, this option being free of charge for orders of 5 units or more. Sustainable production

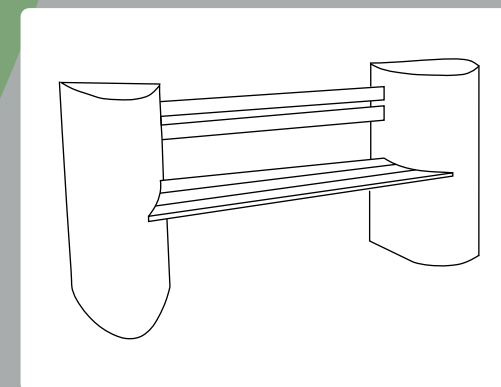

*There is the option of of customised measurements

Ventos Metódicos Reciclagem LDA.
Polígono Industrial da Lagoa. Rua das Cruzes, 484
4950-850 Monção. Portugal

info@sostylair.eu
Teléfono: +34 62686 86 30



GOYO PRO Bench

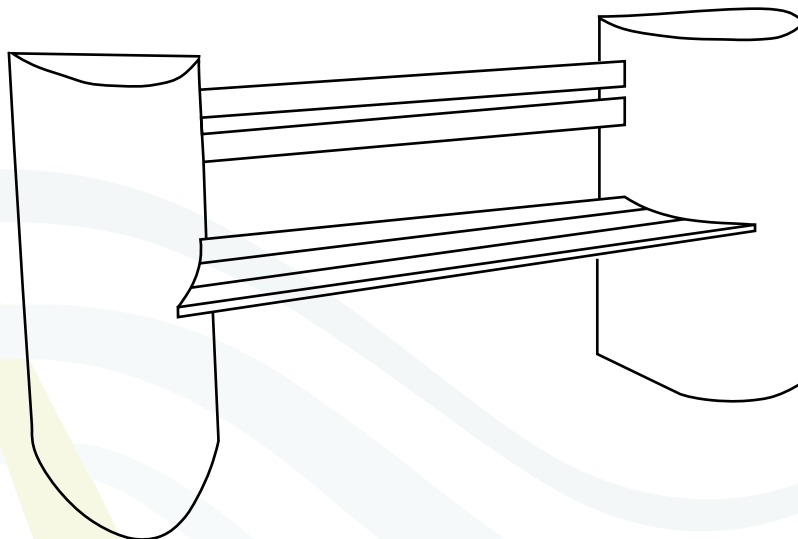



REF: 0007

 Measures *

Length: 224 cm
Width: 50 cm
Height: 95 cm

 Weight
40 Kg

 Endurance
400 Kg/m²

 Paint Temperature
Max. 85°C

 Color
White
Black
Customised

 Content

2 Bases
5 Bars
2 Rear covers
2 Bar supports
6 Screws

 Packaging Measures

Length: 250 cm
Width: 60 cm
Height: 60 cm

 Warranty
2 Years

*Approximate measurements

Made with recycled materials. 95% sustainable.



Polígono Industrial da Lagoa
Rua das Cruzes, nº 484
4950-850 Monção
Portugal

 www.ventosmetodicos.com
 +351 258 099 691





GOYO BENCH

INDOOR / OUTDOOR

Who would say that through a blade from a windmill could be obtained much of the urban and domestic furniture?

SOSTYL AIR[®]

GIVE A SECOND LIFE TO THE SO CALLED EVIL WASTE OF ENERGY WIND POWER FOR ITS RECONVERSION INTO A WIDE RANGE OF PRODUCTS LIKE,

BENCHES, FLOWERPOTS, TABLES, CHAIRS, LAMPS...

ECOLOGICAL AND SUSTAINABLE



DESCRIPTION: Bench for indoor or outdoor use, with two towers on both sides and space to place plants or to store objects.

Measures*:	Height	95 cm
	Width	50 cm
	Length	224 cm
Approximate measurements		

Colour: Basic presentation in white and black color. The customer can customize the external color of the bench according to their needs, with a cost of 50€, this option being free of charge for orders of 5 units or more.
Sustainable production

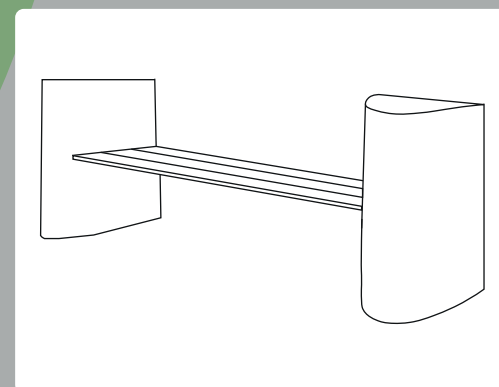

*There is the option of of customised measurements

Ventos Metódicos Reciclagem LDA.
Polígono Industrial da Lagoa. Rua das Cruzes, 484
4950-850 Monção. Portugal

info@sostylair.eu
Teléfono: +34 62686 86 30



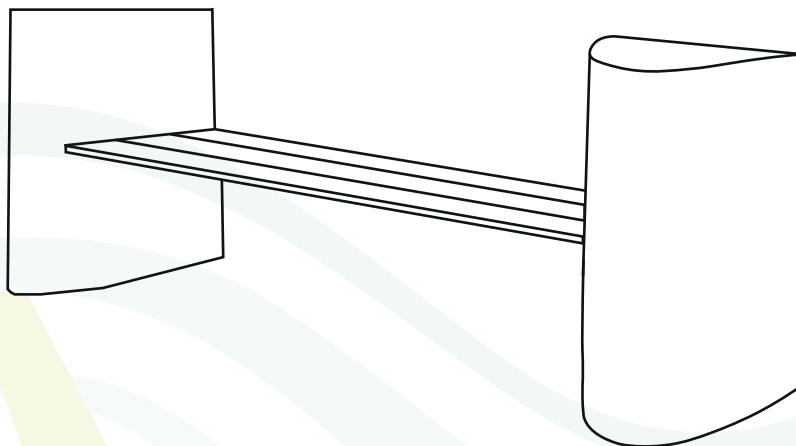

GOYO Bench



REF: 0008

 **Measures***
Length: 224 cm
Width: 50 cm
Height: 95 cm

 **Weight**
35 Kg

 **Endurance**
400 Kg/m²

 **Paint Temperature**
Max. 85°C

 **Color**
White
Black
Customised

 **Content**
2 Bases
3 Bars
2 Bar supports
6 Screws

 **Packaging Measures**
Length: 250 cm
Width: 60 cm
Height: 60 cm

 **Warranty**
2 Years

*Approximate measurements

Made with recycled materials. 95% sustainable.



Poligono Industrial da Lagoa
Rua das Cruzes, n° 484
4950-850 Monção
Portugal

 www.ventosmetodicos.com
 +351 258 099 691





BENCH TEAR

INDOOR / OUTDOOR

Who would say that through a blade from a windmill could be obtained much of the urban and domestic furniture?

SOSTYL AIR[®]

GIVE A SECOND LIFE TO THE SO CALLED EVIL WASTE OF ENERGY WIND POWER FOR ITS RECONVERSION INTO A WIDE RANGE OF PRODUCTS LIKE,

BENCHES, FLOWERPOTS, TABLES, CHAIRS, LAMPS...

ECOLÓGICO Y SOSTENIBLE



DESCRIPTION: Design bench made from the middle part of the wind blade. Valid for indoors and outdoors.

Measures*:

Height	45 cm
Width	50 to 60 cm
Length	160 to 200 and 220 to 250 cm

Approximate measurements

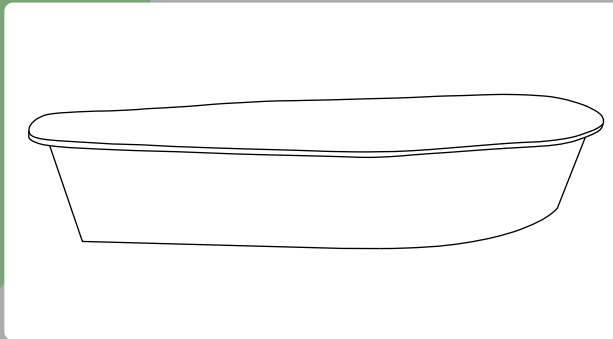

Colour: Basic presentation in imitation wood, imitation sand, white and black color. The customer can customise the external colour of the bench according to their needs, at a cost of 50€, with this option being free of charge for orders of 5 units or more. Sustainable production.

*There is the option of customised measurements

Ventos Metódicos Reciclagem LDA.
Polígono Industrial da Lagoa. Rua das Cruzes, 484
4950-850 Monção. Portugal

info@sostylair.eu

Telefone: +34 62686 86 30



Bench TEAR

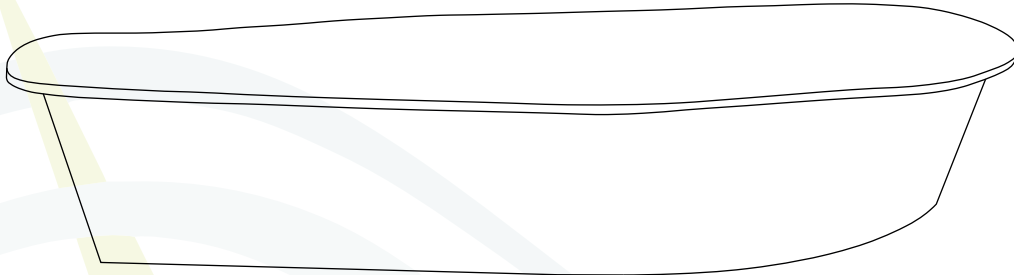

REF: 0028

Measures*

Length: 160 to 200 and 220 to 250 cm
Width: 50 to 60 cm
Height: 45 cm

Weight

35 Kg

Endurance

400 Kg/m²

Paint Temperature

Max. 85°C

Color

White
Black
Wood effect
Stone effect
Customised

Content

1 Base
1 Cover
6 Screws

Packaging Measures

Length: 160 to 200 and 220 to 250 cm
Width: 50 to 60 cm
Height: 45 cm

Warranty

2 Years

*Approximate measurements

Made with recycled materials. 95% sustainable.



Poligono Industrial da Lagoa
Rua das Cruzes, n° 484
4950-850 Monção
Portugal

 www.ventosmetodicos.com
 +351 258 099 691



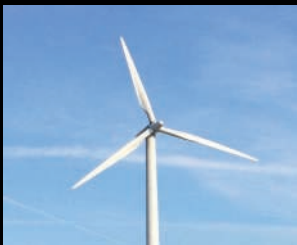

NATURA BENCH

Who would say that through a blade from a windmill could be obtained much of the urban and domestic furniture?

SOSTYL AIR[®]

GIVE A SECOND LIFE TO THE SO CALLED EVIL WASTE OF ENERGY WIND POWER FOR ITS RECONVERSION INTO A WIDE RANGE OF PRODUCTS LIKE,

BENCHES, FLOWERPOTS, TABLES, CHAIRS, LAMPS...

ECOLÓGICO Y SOSTENIBLE



DESCRIPTION: Design bench made from the middle part of the wind blade. Valid for indoors and outdoors.

Measures*:

Height	98 cm
Width	60 cm
Length	215 to 240 cm

Approximate measurements

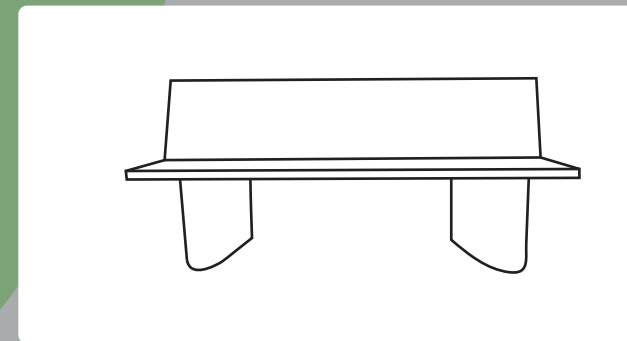

Colour: Basic presentation in imitation wood, imitation sand, white and black color. The customer can customise the external colour of the bench according to their needs, at a cost of 50€, with this option being free of charge for orders of 5 units or more. Sustainable production.

*There is the option of customised measurements

Ventos Metódicos Reciclagem LDA.
Polígono Industrial da Lagoa. Rua das Cruzes, 484
4950-850 Monção. Portugal

info@sostylair.eu

Telefone: +34 62686 86 30



NATURA Bench



REF: 0036

Measures*

Length: 215 to 240 cm
Width: 60 cm
Height: 98 cm

Weight

35 Kg

Paint Temperature

Max. 85°C

Color

White
Black
Wood effect
Stone effect
Customised

Content

1 Natura Bench

Packaging Measures

Length: 215 to 240 cm
Width: 60 cm
Height: 98 cm

Warranty

2 Years

*Approximate measurements

Made with recycled materials. 95% sustainable.



Poligono Industrial da Lagoa
Rua das Cruzes, n° 484
4950-850 Monção
Portugal

 www.ventosmetodicos.com
 +351 258 099 691

